

SEE IS1023 FOR SERVICE INSTRUCTIONS.
LUBRICATE ALL SEALS WITH CLEAN HYDRAULIC OIL
PRIOR TO ASSEMBLY.
DO NOT USE SILICONE BASED LUBRICANTS.

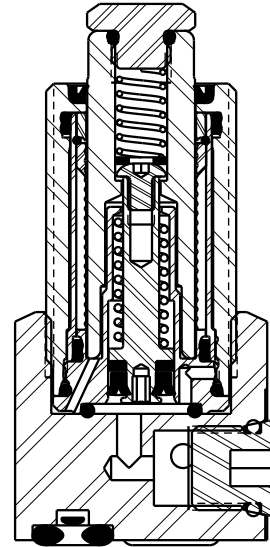

PLUNGER
These work supports are fully rebuildable to full factory original capacity by any authorized Vekttek repair facility. All seals can be replaced by any authorized repair facility.

BODY ASSEMBLY
-NOT REPLACEABLE
TORQUE TO 35 FT-LB

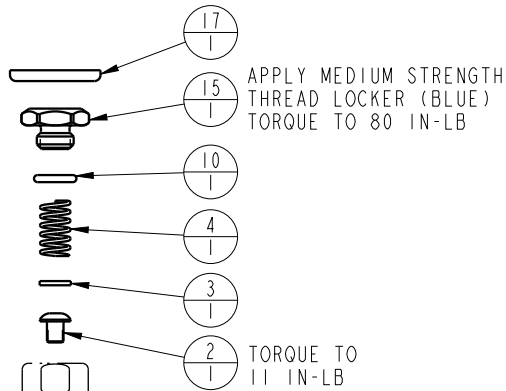
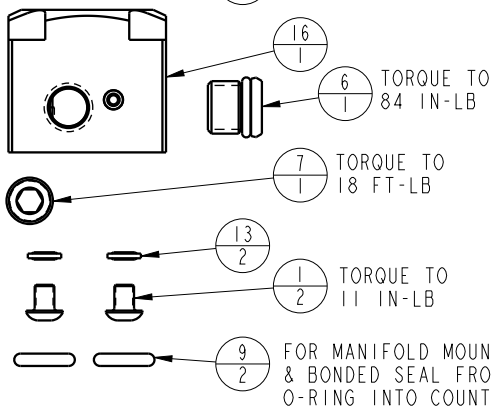
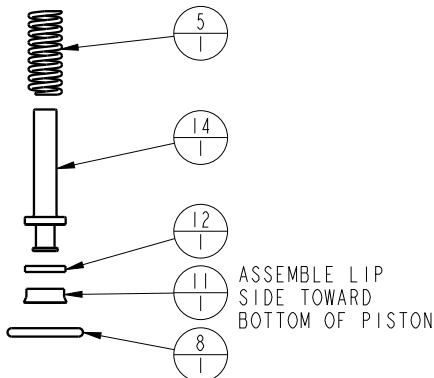

NO	QTY	PART NO	DESCRIPTION	STD SEAL KIT	SPRING KIT
1	2	21410006	BHCS, 8-32 x 1/4, SST		
2	1	21410076	BHCS, 6-32 x 3/16 SELFLOCK, SST		
3	1	21430012	WASHER		
4	1	23350060	SPRING, COMPRESSION		X
5	1	23350122	SPRING, COMPRESSION		X
6	1	30601144	PLUG, SOCH, SAE 4		
7	1	30603322	PLUG, PIPE, HEX, HOL, 1/8 NPT, STEEL		
8	1	39050008	O-RING, (-014)	X	
9	2	39051012	O-RING, (-109)	X	
10	1	39051059	O-RING, (6mm x 1.5)	X	
11	1	39052057	SEAL, BEVEL, 3/32 X 5/32 X 11/32	X	
12	1	39054035	BU RING, (.157 X .089)	X	
13	2	39055022	SEAL, BONDED, M4		
14	1	81010615	PISTON, WS, FA, HC, 2000		
15	1	81040602	BOLT, CONTACT, WS, FA, 1000		
16	1	91040614	KIT, BASE, WS, FA, MM, HC, 2000, PPS		
17	1	39V53003	WIPER, PRESS-IN, (9/16), VBGV	X	
N/A	N/A	60100128	KIT, SEAL, WS, FA, BM, HC, 2000	NOTED	N/A
N/A	N/A	61100223	KIT, SPRING, WS, FA, HC, 2000	N/A	NOTED
N/A	N/A	IS1023	INSTRUCTION SHEET	N/A	N/A

PARTS LIST



VEKTEK, INC.
1334 E. SIXTH AVE. P.O. BOX 625
EMPORIA, KS. 66801 U.S.A.

ASSEMBLIES AFFECTED
10080620

SIZE A
PL1095

REV B

B	4096	RELEASE	MJUST	3/27/20
REV	IN ACCORDANCE WITH ECN	EFFECTIVE DATE	REVISED BY	DATE
DRW BY:	BCD	DRAWING STATUS: Released		
DATE:	7/28/18	PRODUCTION APPROVED FOR RELEASED STATUS ONLY		

FORM FEG035_PL_ASIZE, REV. B

SHEET 1 OF 1

Vekttek LLC 1334 East Sixth Ave. P.O. Box 625 Emporia, Ks. 66801 U.S.A.	Instruction Sheet	IS	1023	
		REV:	C, I.A.W ECN3930	
		REV. BY/DATE:	ALS	10/03/19
		APPR/DATE:	TDK	10/04/19
TITLE: Disassembly/Assembly Instructions: Inch and Metric High Capacity Fluid Advance Work Supports				

These work supports are fully rebuildable to full factory original capacity by any authorized Vekttek repair facility. All seals can be replaced by any authorized repair facility.

Read all instructions prior to disassembling!

Refer to the illustration on page three for component part numbers and tool list.

Disassembly

1. Unscrew the cartridge assembly (8) from the base (14) or fixture. **Caution- Use a six-point socket only. Other types of wrenches may damage the work support.**
2. Hold the plunger (5) stationary and unscrew the contact bolt (1). Remove contact o-ring (15) from contact bolt (1).
3. Remove the spring (2) and spacer (9) from inside the plunger (5).
4. Hold the piston (7) stationary and unscrew the cap screw (3).
5. Slide the plunger (5) out of the top of the cartridge assembly (8) and then push the piston (7) and spring (12) out of the retainer (13).
6. Remove the wiper (6) from the cartridge assembly (8).
7. Remove the piston seal (10) and piston seal back-up ring (11) from the piston (7), and the seal (4) from the base (14) or fixture.
8. Clean all parts thoroughly and set aside to dry.

Vekttek LLC 1334 East Sixth Ave. P.O. Box 625 Emporia, Ks. 66801 U.S.A.	Instruction Sheet	IS	1023	
		REV:	C, I.A.W ECN3930	
		REV. BY/DATE:	ALS	10/03/19
		APPR/DATE:	TDK	10/04/19
TITLE: Disassembly/Assembly Instructions: Inch and Metric High Capacity Fluid Advance Work Supports				

Assembly

1. Lubricate all O-rings, gaskets, back-up rings and seals with clean hydraulic fluid (Vekttek 65-0010-01 or equivalent). Apply Loctite primer N® or equivalent to the threads of the contact bolt (1) and the retainer (13) and set aside to dry.
2. First install the back-up ring (11) then the piston seal (10) onto the piston (7) with the sealing lips of the piston seal (10) toward the piston (7) base.
3. Slide the spring (12) onto the piston (7) and insert both parts into the retainer (13).
4. Insert the plunger (5) into the top of the cartridge assembly (8).
5. While holding the piston (7) stationary insert the cap screw (3) into the top of the plunger (5) and thread the cap screw (3) into the piston (7). Tighten to the specification on the parts list.
6. Insert the flat washer (9) and the spring (2) into the top of the plunger (5).
7. Install contact o-ring (15) onto contact bolt (1). Apply one drop of Loctite 243® or equivalent to the threads of the contact bolt (1). While holding the plunger (5) stationary tighten the contact bolt (1) to the plunger (5). Tighten to the torque specification on the parts list.
8. If using o-ring, place the o-ring (4) flat in the bottom of the retainer (13). Insert the work support assembly into the base (14) or mounting cavity and tighten it to the torque specification on the parts list.
Caution- Use a six-point socket only. Other types of wrenches may damage the work support. Note- Use o-ring if cavity abides by ILS100716, ILS100717, or ILMV100723. Use o-ring OR gasket, not both.
9. If using gasket, place the gasket (4) flat in the bottom of the base (14) or mounting cavity. Insert the work support assembly into the base (14) or mounting cavity and tighten it to the torque specification on the parts list.
Caution- Use a six-point socket only. Other types of wrenches may damage the work support.

Vektek LLC 1334 East Sixth Ave. P.O. Box 625 Emporia, Ks. 66801 U.S.A.	Instruction Sheet	IS 1023	
		REV: C, I.A.W ECN3930	
		REV. BY/DATE: ALS	10/03/19
		APPR/DATE: TDK	10/04/19
TITLE: Disassembly/Assembly Instructions: Inch and Metric High Capacity Fluid Advance Work Supports			

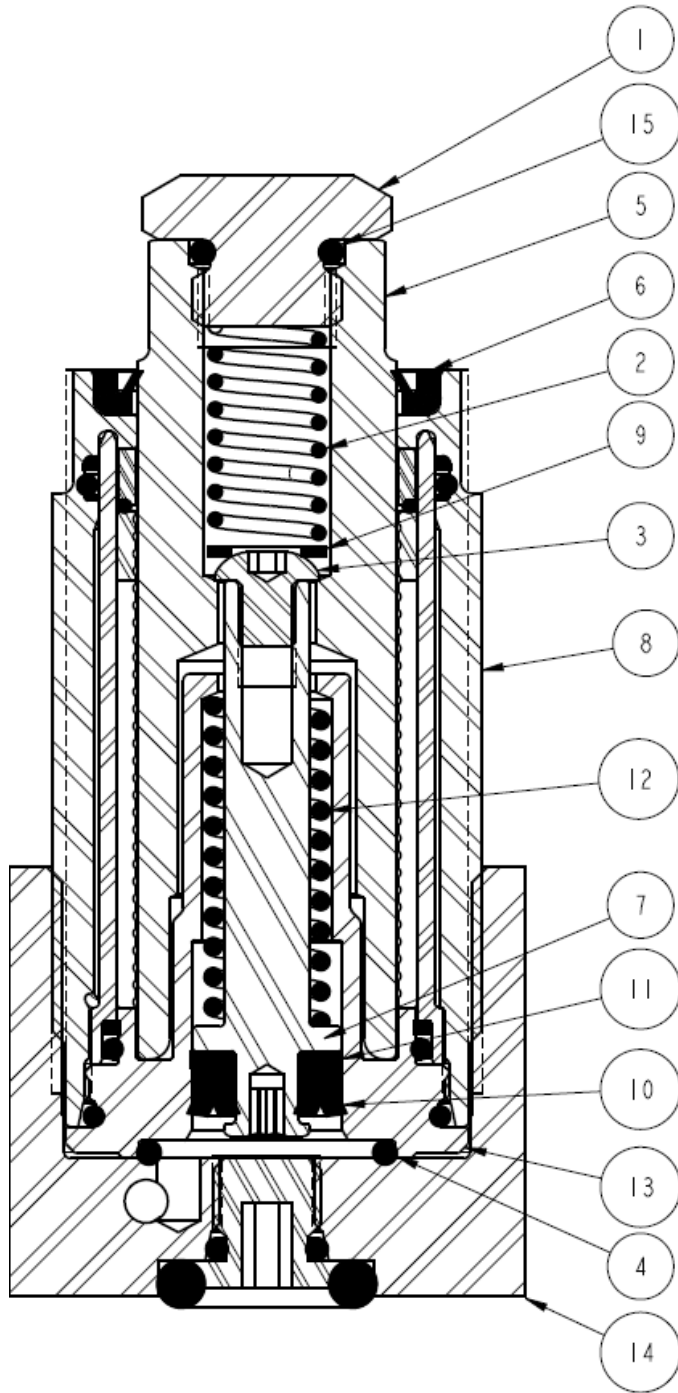

15	CONTACT O-RING
14	BASE
13	RETAINER
12	CONTACT SPRING
11	BACK-UP RING
10	PISTON SEAL
9	FLAT WASHER
8	CARTRIDGE ASSY
7	PISTON
6	WIPER
5	PLUNGER
4	SEAL
3	CAP SCREW
2	CONTACT SPRING
1	CONTACT BOLT
Item	Description